

香港工商業獎

2016

HONG KONG
AWARDS FOR
INDUSTRIES



TECHNOLOGICAL
ACHIEVEMENT
科技成就

2016 Hong Kong Awards for Industries: Technological Achievement

2016 香港工商業獎：科技成就

Grand Award

Comba Telecom Systems Holdings Limited
京信通信系統控股有限公司 4

Award

Dao Lab Limited
立道研究所有限公司 8

Health View Bioanalytic Limited
康訊生物分析有限公司 10

Nano and Advanced Materials Institute Limited
納米及先進材料研發院有限公司 12

Well Being Digital Limited
衛保數碼有限公司 14

Certificate of Merit

4M Industrial Development Limited
科文實業有限公司 16

Cenique Infotainment Group Limited
怡能媒體有限公司 17

ClusterTech Limited
聯科集團(中國)有限公司 18

Digpro Group Limited
迪普集團有限公司 19

Eggplant Technologies Limited
茄子科技有限公司 20

Farm66 Investment Limited
綠芝園投資有限公司 21

Seve Studio 22

Spring Eco-Tech Limited
淵源綠色科技有限公司 23

Technoform BAUTEC Hong Kong Limited
香港泰諾風保泰有限公司 24

Chairperson's Message 主席的話

On behalf of the Hong Kong Science and Technology Parks Corporation (HKSTP), it is my great pleasure to congratulate all winners of the 2016 Hong Kong Awards for Industries (HKAI).

The achievements of the award winners reaffirm my optimism in the future of Hong Kong industries. As the Lead Organiser for the "Technological Achievement" awards, we are pleased to see many of the winning technologies already successfully commercialised and are serving the needs of our society. They are solid evidence that Hong Kong's industries are moving towards the upper end of the value chain.

There are technologies for enhancing mobile telecommunication to meet the increasing demand for high speed data transmission, as well as a new form of video compression technology that broadens our choice of infotainment. There are smart devices that enable early detection of critical diseases and stylish wearables to monitor one's health, as well as invention of flexible and super safe batteries based on nano technology that forms the basis for even cooler products. There are also technologies to enhance our lifestyle, from VR enhanced toys to smart urban farming, and tools that can glean business intelligence from social media across different languages.

These winning innovations highlight the increasing sophistication of Hong Kong's home-grown technologies and their potential for global application. They also give us a glimpse of how technology enables smarter lifestyle, smarter business and smarter city. Our vision of diversifying Hong Kong's economic base with the manufacturing of high value products is on the right track, and will lead to more sustainable development. HKSTP stands ready to support the new generation of technology industrialists.

Once again, congratulations to Hong Kong technopreneurs and industrialists!

Fanny Law, GBS, JP
Chairperson, HKSTP



我很高興再度見證一年一度的業界盛事「香港工商業獎」，並謹代表香港科技園公司，向所有得獎者致以至誠的祝賀。

各得獎者的成就，使我更堅信香港工商業的未來發展更形樂觀。香港科技園公司主辦其中「科技成就」組別，縱觀各得獎科技，都是切合社會需要的發明，而且成功地商品化，發掘市場價值，令人感到欣喜，亦證明香港工商業在一股創新幹勁的推動下，不斷邁向產業鏈的高端。

「科技成就」組別的得獎產品中，有提升流動通訊網絡的技術，以應對高速數據傳輸的需求；也有視像壓縮科技，讓資訊娛樂的發展更多元化；創新的智慧裝置與時尚可穿戴科技工具，賦予人們及早察覺危疾病患和更容易掌握個人的健康狀況；還有以納米技術研發出來更具彈性、更安全的電池，將成為發展更多尖端科技產品的基礎；當中更有不少提升生活質素的科技，包括採用擴增實境技術（AR）研發的智能益智教育玩具、在密集的城市開拓綠色耕種的園藝科技，以及發掘網上媒體不同語言內容蘊藏的商業情報的科技工具等等，可見百花齊放。

這一切充滿啟發性的創新得獎產品，反映了本地的創新科技越來越成熟，亦具備國際化的潛質，彰顯了創新科技對推動智慧生活、智慧營商及智慧城市，有著實實在在作用，並且有助能推動香港的工商業持續走向高端化，促進香港的經濟發展更多元。香港科技園公司會秉承一貫的使命，為本地科創生態圈注入無窮動力，扶植本地新一代的科技工業家不斷進步。

在此，我再次祝賀香港科技企業家和工業家值得嘉許的成就！

香港科技園公司主席
羅范椒芬 GBS, JP

2016 Hong Kong Awards for Industries
Customer Service, Innovation and Creativity, Productivity and Quality,
Technological Achievement and Upgrading and Transformation
二〇一六香港工商業獎
顧客服務、創意、生產力及品質、科技成就、升級轉型組別

Final Judging Panel 最終評審委員會



From Left:

Ms Ruth Yu

Executive Director
Hong Kong Retail Management Association

Mr Emil Yu

Chairman, Industry & Technology Committee
Hong Kong General Chamber of Commerce

Dr Lawrence Cheung

Director, Technology Development
Hong Kong Productivity Council

Prof Joseph JY Sung

Chairman of the Final Judging Panel
Vice-Chancellor and President
The Chinese University of Hong Kong

Ms Maria Lam

Chief Marketing Officer
Hong Kong Science and Technology Parks Corporation

Dr Jacky Cheung

Ex-officio Advisor
Hong Kong Young Industrialists Council

Ms Belinda Wong

Assistant Director - General of Trade and Industry
Trade and Industry Department
(not judging panel member)

由左起：

余麗姚女士

香港零售管理協會執行總監

于健安先生

香港總商會工業及科技委員會主席

張梓昌博士

香港生產力促進局副總裁 (科技發展)

沈祖堯教授

最終評審委員會主席
香港中文大學校長

林淑芬女士

香港科技園公司首席市務總監

張華強博士

香港青年工業家協會當然顧問

王婉蓉女士

工業貿易署助理署長
(非評審委員會成員)

Judging Panel 評審委員會



From Left:

Dr. Ken Yeung

General Manager, Biologics and GMP Consultation Department
The Hong Kong Institute of Biotechnology Limited

Ir Dr. Chak Man Ng

Immediate Past Chairman, IT Division
The Hong Kong Institution of Engineers

Dr. Lawrence Cheung

Director, Technology Development
Hong Kong Productivity Council

Mr. Kenny Yiu

Chairman
Hong Kong Wireless Technology Industry Association

Prof. On Ching Yue

Science Advisor
Innovation and Technology Commission, HKSARG

Dr. CH Ng

Chairman
The Hong Kong Electronic Industries Association

Mr. Andrew Young

Chief Commercial Officer
Hong Kong Science and Technology Parks Corporation

Prof. Andy Hor

Vice-President and Pro-Vice-Chancellor (Research)
The University of Hong Kong

Ir Victor Ng

Chairman
Hong Kong Electronics & Technologies Association

Mr. Andy Bien

Vice President (Membership Growth)
Hong Kong Computer Society

Prof. Jian Lu

Vice-President (Research & Technology) and Dean of Graduate Studies
City University of Hong Kong

Prof. Enboa Wu

Associate Vice-President (Knowledge Transfer)
The Hong Kong University of Science and Technology

Ir Prof. Ping-kong Alexander Wai

Vice President (Research Development)
The Hong Kong Polytechnic University

Prof. Kam Fai Wong

Associate Dean (External Affairs), Faculty of Engineering
The Chinese University of Hong Kong

由左起：

楊樹英博士

香港生物科技研究院生物製品及GMP顧問服務部
總經理

伍澤文博士

香港工程師學會資訊科技分部上任主席

張梓昌博士

香港生產力促進局副總裁 (科技發展)

姚金鴻先生

香港無線科技商會主席

余安正教授

香港特別行政區政府創新科技署科學顧問

吳自豪博士

香港電子業商會會長

楊孟璋先生

香港科技園公司首席商務總監

賀子森教授

香港大學副校長 (研究)

吳國豪先生

香港電子科技商會主席

卞家振先生

香港電腦學會副會長 (會員事務)

呂堅教授

香港城市大學副校長 (研究及科技) 及研究生院院長

吳恩柏教授

香港科技大學協理副校長 (知識轉移)

衛炳江教授

理工大學副校長 (科研發展)

黃錦輝教授

香港中文大學工程學院副院長 (外務)

Technological
Achievement
Grand Award
科技成就大獎

Comba

Comba Telecom Systems Holdings Limited
京信通信系統控股有限公司

Comba Telecom is one of the leading wireless communication solution providers in the world. We create, develop and produce the industry most advanced 2G, 3G and 4G wireless network technologies including wireless enhancement, wireless transmission, antennas & subsystems and wireless access. We create added value to mobile operators and enterprises to enhance and extend their wireless communications networks by integrating these advanced technologies through our end-to-end solutions and services around the world. Comba also provides complete turnkey solutions and services to its global customers including consultation, network design, optimization and commissioning.

Headquartered in Hong Kong, Comba Telecom's global operations include R&D headquarters based in Guangzhou Science City, R&D centers in China and USA, and more than 40 offices worldwide. Comba has a strong task force with over 8,400 employees worldwide in our 60+ direct offices and points-of-presence covering all rounded sales supports in Asia Pacific, Europe, Middle East, Africa, Australia and the Americas.

Established in 1997, Comba Telecom listed on the Hong Kong Stock Exchange in 2003 (2342.HK). Comba Telecom has been included into several indexes including MSCI China Small Cap Index, Hang Seng Composite Index (Information Technology Industry Index, MidCap & SmallCap Index and SmallCap Index), Hang Seng Global Composite Index, Hang Seng Internet & Information Technology Index, as well as Hang Seng Corporate Sustainability Benchmark Index.

京信通信是全球領先無線解決方案供應商之一，為業界創造、建立及生產最先進的2G、3G及4G無線網絡技術，包括無線優化、無線傳輸、天線與基站子系統及無線接入。我們透過端對端的解決方案及服務集成這些先進的技術，為世界各地的流動營運商和企業提供基礎設施和解決方案，增強網絡效率，擴大網絡覆蓋範圍，創造更多價值。集團亦為全球客戶提供全面網絡優化解決方案及服務，包括方案設計、安裝、網絡優化、售後維修服務、技術諮詢等。

京信通信企業總部設於香港，營運網絡遍佈全球，包括在中國廣州科學城設有總部研發基地、設於中國和美國的研發中心、以及全球超過40間辦事處。京信通信擁有強大的專業團隊，超過8,400名員工在位於亞太地區、歐洲、中東、非洲、澳洲及美洲等地的60多個直屬辦事處及分支機構，為全球客戶提供全方位的銷售網絡支援。

自1997年成立以來，京信通信在業內表現突出，並於2003年在香港聯交所主板上市（2342.HK）。京信通信現已獲納入多項指數，包括MSCI中國小型股指數、恒生綜合指數（資訊科技業指數、中小型股指數及小型股指數）、恒生環球綜合指數、恒生互聯網科技業指數及恒生可持續發展企業基準指數。



R&D headquarters based
in Guangzhou Science City
廣州科學城研發基地總部

The Grand Award winning Comba **ComFlex Modular Fiber Optical Repeater system** is an important building block of indoor distributed antenna system for commercial public mobile telecommunication network as well as private mobile network. The ComFlex system includes two main components: **Master Unit (MU)** - the interface for mobile base station and **Remote Unit (RU)** - the amplification unit. The system utilizes a single optical fiber to support multiband and duplex operation.

Since the launch of ComFlex system in the market, it was widely adopted in different applications such as large venue, shopping mall, high speed railway, tunnel, metro and stadium globally. E.g. Hong Kong Express Line and 2014 World Cup stadiums etc. It provides a ubiquitous wireless connection for mobile users around the world.

是次榮獲科技成就大獎的京信**COMFLEX模塊化光纖直放站系統**是室內分佈式天線系統的一個重要組成部分，主要用於提高商用公共移動通信網以及專用移動網絡的室內覆蓋。該COMFLEX系統包括兩個主要組成部分：**中繼端（MU）** - 用於移動基站的接入及**遠端（RU）** - 放大單元。該系統利用單一條的光纖，便可以支持多頻帶和全雙工的操作。

自COMFLEX系統在市場上推出以來，一直被廣泛應用在全球不同的場合，如大型場館、商場、高速鐵路、隧道、地鐵和體育場等，例如廣深港高速鐵路（香港段）、巴西里約熱內盧2014世界杯場館等，為世界各地用戶提供一個無處不在的移動連接環境。

ComFlex Master Unit
ComFlex 光纖直放站 -
中繼端



The key attributes of ComFlex system include:

Modular design – the modular design supports highly flexible frequency band and redundancy configuration to adapt different scenario and requirement especially in subway or railway tunnel.

Flexible system architecture – it supports daisy chain of multiple RU cluster for coverage extension.

High power efficient and linear amplifier technologies – patented technologies to support multiple-technologies, multiple operators, signal amplification, as well as minimize the distortion of the original signal in high power application.

Robust fanless mechanical design – especially designed to weather in extremely harsh environments.

COMFLEX系統的關鍵特性包括：

模塊化設計 – 模塊化設計支持高度靈活的頻段和後備配置，以適應不同的場景，尤其在高要求的地鐵或高速鐵路隧道環境。

靈活的系統架構 – 可以鏈接多個RU成為集群，擴展覆蓋範圍。

高功效和線性放大器技術 – 獲得多項專利技術。支持不同科技及放大多運營商的信號，並能以最大限度減少在高功率應用的原始信號的失真。

堅固的無風扇結構設計 – 擁有特別設計，能在極其惡劣的環境下使用。



ComFlex Remote Unit
ComFlex 光纖直放站 - 遠端

ComFlex system provides a ubiquitous wireless connection to the mobile users of 2014 World Cup stadiums
ComFlex 系統為巴西里約熱內盧 2014 世界杯場館用戶，提供一個無處不在的移動連接環境



The ComFlex system, built with Comba's innovative technology and experience in the industry, will continue to improve and contribute to the advancement of the telecommunication industry.

For further information about Comba and its products and solutions, please visit: www.comba-telecom.com

配合京信通信創新的技術和行業經驗，COMFLEX系統將繼續改善及促進電信業的發展。

更多關於京信通信的產品及解決方案，請瀏覽www.comba-telecom.com。

Comba's manufacturing base covers an area of 42,000+ square meters
京信通信擁有超過4.2萬平方米的標準通信設備製造廠房



Technological
Achievement
Award
科技成就獎



Dao Lab Limited
立道研究所有限公司

Dao Laboratory is a Hong Kong Science Park based company founded by Kit Tsin in 2007. Kit left Cambridge University in the UK to start his first business in 1998 and since that has been successfully created two technology businesses. Dao Lab focus on the R&D of video compression technology and their Volo family of encoders has been well received among leading Hong Kong and overseas media companies including TVB.COM, PCCW Global, Viu and was elected the best Video Encoder in Latin America.

Dao has recently partner with Amazon Web Service, the largest cloud provider in the world, to offer a joint technology showcase using Dao's cutting edge Volo high speed parallel transcoding technology. This is the first of its kind of bring a breakthrough of HEVC and 4K compression speed to mass market.

It has taken over 7 years of intensive R&D, all done locally in Hong Kong, to create a cutting edge new technology innovation on existing H.264 and the new HEVC standard. Dao Lab achieved its success by overcoming

立道是一家於2007年創辦及建基於香港科技園的公司。創辦人冼漢傑自1998年離開劍橋大學以後分別成立了兩家成功的本土企業，取得了外國資金並被美國上市公司所收購。立道公司的視像壓縮產品，由於具有遠超同類產品的壓縮效率水平，故廣泛地應用於本地主要領先媒體公司，包括TVB最新數十萬用戶的Super go TV 機頂盒點播服務，及廣受歡迎的Viu.com OTT 服務。立道公司更成為PCCWG 全球影像壓縮技術的合作夥伴。

立道公司的影像壓縮技術超卓及其於壓縮速度上的領域有技術突破，得到不少海外公司的認同，並於十一月與美國Amazon公司攜手於香港向各大主要媒體公司展示該公司的高速壓縮技術，配合 Amazon 雲端平台所帶來前所未有的壓縮速度及質素優勢。

立道公司的技術研究及開發經歷七年時間之長，為本地研發之成就。公司克服多種技術上的挑戰，於現有的H.264及HEVC 技

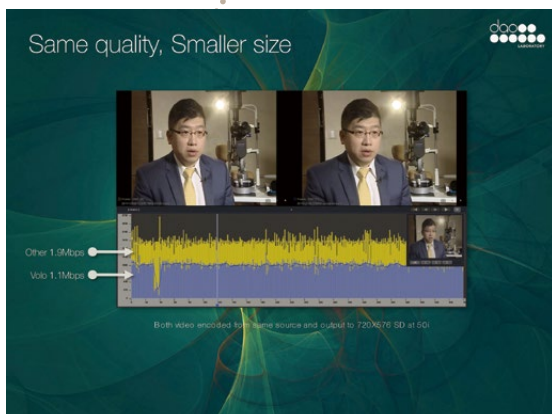

Same quality,
Smaller size
影片質素相同，
檔案更小

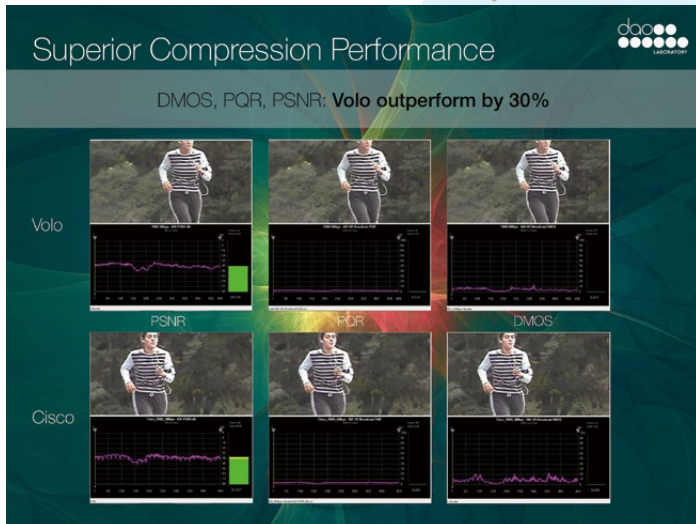

Superior Compression Performance
卓越壓縮效能

major technology challenges and to innovate and enhance upon well-established video compression standards. It demands truly creative minds and a thinking out of the box. The Dao Lab Volo product excels in both compression efficiency, speed, and at the same time, achieve full compliance to myriad of strict industrial standards in broadcast and OTT industry. With Kit's distributed and parallel computing background during his research at Cambridge, Dao Lab is able to combine Information theory with cutting edge distributed computing technology to break the speed barrier of Ultra High Definition video compression.

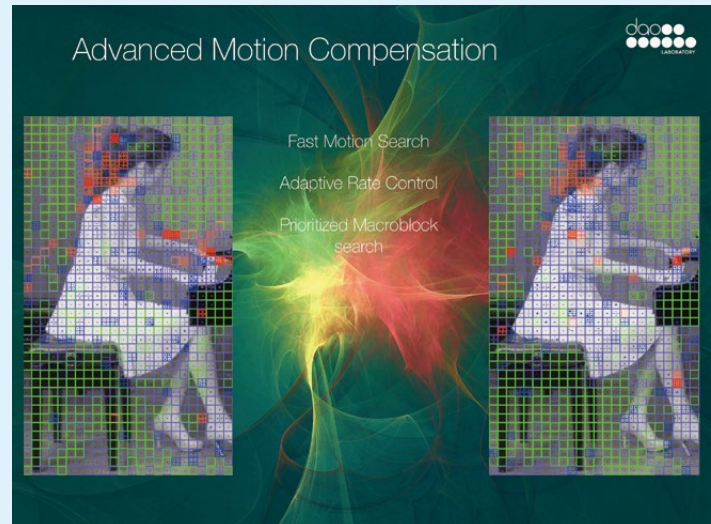

Advanced Motion Compensation
進階動作補償

術標準下 作出基本運算及實現層面上的多種優化，從而取得壓縮效率及速度上的優勢。在現今及未來日漸普及的超高清及多元視訊服務平台上，該公司的產品在全球市場具有很大的競爭力。

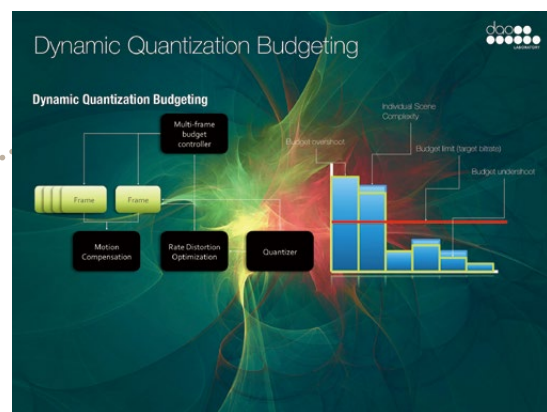

Dynamic Quantization Budgeting
動態量化預算

Technological
Achievement
Award
科技成就獎



Health View Bioanalytic Limited
康訊生物分析有限公司



Life demo in a conference exhibition area
展覽會現場演示

Health View Bioanalytic Limited (HVB) provides a cloud-based fully automatic retinal image analysis (ARIA) platform for assessing the risks of various diseases such as stroke, diabetic retinopathy, coronary heart disease, chronic kidney disease, age-related macular degeneration, and dementia. Since retinal blood vessels are connected with the brain and other parts of the body, we can use this portion of blood vessels to estimate overall vascular health related problems. Our first product provides a fast and convenient stroke risk assessment for general population, elderly and even patients with chronic diseases such as diabetes and hypertension.

Rising global aging population requires screening for health promotion and disease prevention. People need to decode their risks and change their lifestyle to live longer and healthier. With a picture on the back of the eyes, we provides a convenient way to decode the risk of stroke and many other blood vessels related diseases caused by hypertension,

康訊生物分析有限公司於2015年初成立，以香港中文大學的科研為基礎，提供全球首創的「全自動視網膜圖像分析系統」(ARIA)。上載一幅眼底相到互聯網，便可隨時隨地快速準確地評估中風及多個與心血管相關疾病的風險。ARIA技術已於2014年獲取美國專利。因眼底血管與腦部以至全身血管相連，所以能從眼底的血管評估整體心血管狀況，為一般市民，尤其是患糖尿病、高血壓、心臟病、恐懼抽血及不願到診所驗身的人仕，提供方便快捷的中風風險評估。而且目標用戶十分廣泛，包括復康中心、醫療健康中心、驗光單位、社區衛生服務中心、保險公司、全科醫生、護理院等。

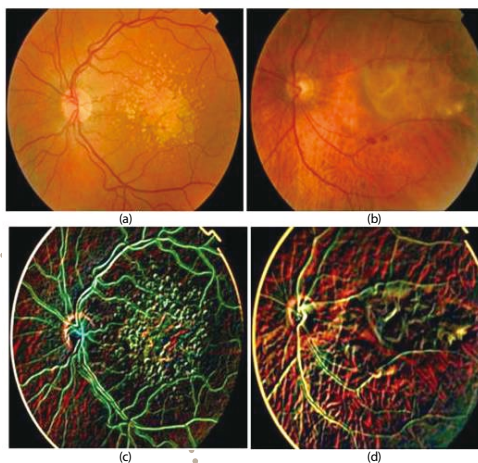

Retinal images (a), (b)
before and (c), (d) after
transformation and
filtering
視網膜圖像變換和濾波前
(a), (b)、後 (c), (d)

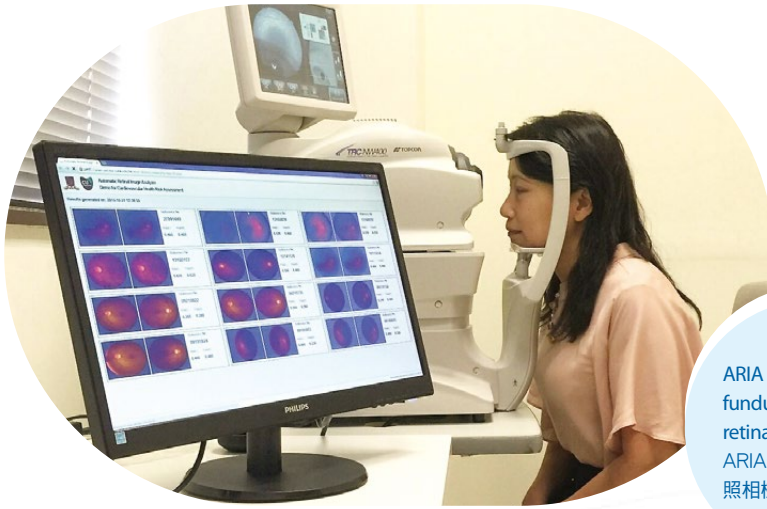

ARIA use a simple fundus camera to take retinal image
 ARIA使用簡單的眼底照相機拍攝視網膜圖像

diabetes, and lipid abnormalities. We have made our product convenient and easy to use so that people in the community are able to manage their own health before they have the disease with irreversible consequence, and may avoid millions of deaths and disabilities that affect people's health and their family. We have already launched ARIA-stroke in Hong Kong. Our clients include optometry shops, family physicians, health check laboratories, nutrition companies, insurance companies and social service organizations. People may avoid life threatening event and potential disability by changing their lifestyle, diet, exercise, and may seek medical advice only if they know their risk of stroke at a very early stage.

康訊相信將來的醫療保健的主要焦點是「創新科技」，尤其是應用在「預防醫學和早期篩查」的領域上，更能有效地提高整體社會的健康水平。隨著社會面對「人口老齡化」及「危疾年輕化」的壓力，康訊的科研也正針對這問題作為我們研發的目標。創新科技能把更多健康檢查普遍應用到基層醫療甚至家居中，把中國傳統「治未病」的概念，以高科技的方法更方便省時地提供給普羅大眾，在危疾未發以先，便已提高了我們個別對自己健康的警覺，可把危疾的發病率大大減低。康訊一向以服務社會為己任，在全球創新創業的大方向上堅持以「科研創業 回饋社會」為目標，與志同道合的社會賢達共同努力。



Prof. Benny Zee (right) and Dr. Jack Lee (left) of Health View Bioanalytic Ltd.
 康訊生物分析有限公司徐教授(右)及李博士(左)

Technological
Achievement
Award
科技成就獎



Nano and Advanced Materials Institute Limited
納米及先進材料研發院有限公司

Revolutionary Flexible Battery Technology for Wearable Electronics

Wearable and flexible gadgets are poised to become the next major trend in IoT electronics. However, the types of battery being used currently are all quite “stiff” and occupy valuable space inside the devices. The space versus energy capacity trade off often limits device stand-by time.

With its expertise in nanofiber technology, Nano and Advanced Materials Institute Limited (NAMI) has developed highly flexible, super-safe, powerful and rechargeable lithium ion batteries based on nanofiber sponge electrolyte.

Highly flexible – NAMI’s battery can maintain a very stable voltage output when being bent or even folded at different angles, while conventional lithium ion batteries with liquid electrolyte can never deliver such performance.

Super safe – As there is no free-standing electrolyte in the battery, NAMI’s flexible battery can be kept operational even when cut. It is also stable under extremely high temperature.

Powerful – The capacity of NAMI’s flexible battery is 50 times higher than a leading brand in the market and is comparable to conventional lithium ion batteries.

可穿戴電子的革命性柔性電池

可穿戴及柔性的小型電子產品，勢將成為物聯網電子領域的主要發展趨勢。但此類電池大多比較硬身，佔用電子產品內寶貴的空間。而現今市場上的電池往往因為在空間與能量容量的取捨下限制了電子產品的待機時間。

憑藉在納米纖維技術上的專業知識，納米及先進材料研發院(NAMI)利用納米纖維海綿電解質，開發出高柔性、非常安全、高強度及可充電的鋰離子電池。

高柔性 – NAMI的柔性電池在不同角度屈曲甚至折疊時，仍能維持十分穩定的電壓輸出；相反，一般液體電解質的傳統鋰電池並沒有此性能。

非常安全 – 由於NAMI的柔性電池內沒有獨立存在的電解質，即使被折斷仍可正常運作，而且在極度高溫下仍然保持穩定狀態。

高強度 – NAMI的柔性電池容量較市場上的領先品牌高出50倍，相當於傳統的鋰離子電池容量。

The flexible Li-ion battery is integrated to a smart watch strap to boost battery life
柔性鋰電池被裝嵌在智能手錶錶帶，為錶身充電





NAMI is dedicated to support local enterprises for technology upgrade and commercialization
NAMI 致力支援本地企業，進行技術提升及商品化



NAMI will upgrade the flexible batteries to keep abreast of the latest developments of the wearable electronic devices
NAMI 將不斷提升柔性電池性能，與可穿戴電子設備的最新發展全面配合

Rechargeable – Charging of NAMI’s flexible battery is 20 times faster and life cycle 20 times longer than current brands in the market.

NAMI’s flexible battery is integrated into commercial smart watch as a detachable battery strap to boost battery life, substantially increasing the battery capacity and device operation time by 5 days. NAMI’s flexible battery will be further upgraded and with wider applications to keep abreast of the latest developments of the wearable electronic devices.

NAMI is designated by the Hong Kong Government as a Research and Development Center for nanotechnology and advanced materials. With over 160 research experts and cutting-edge facilities, NAMI supports Hong Kong industries by offering frontier applied research on materials as well as technology transfer.

可充電 – 與現時市場上的品牌比較，NAMI的柔性電池充電時間快20倍，而充電循環壽命亦長20倍。

NAMI的柔性電池已應用在智能手錶上，被裝嵌於可拆卸的軟身錶帶內，為錶身充電，大幅提高電池容量及延長操作時間達5天。NAMI的柔性電池性能將進一步提升，全面配合可穿戴電子設備的最新發展。

NAMI是由香港政府指定為納米科技和先進材料的研發中心。NAMI有超過160位研究專才及尖端的設備，全力支持本港工業進行嶄新的應用研究及技術轉移。

NAMI’s flexible battery is super-safe and operational even when being cut
NAMI的柔性電池非常安全，即使被折斷仍可正常運作

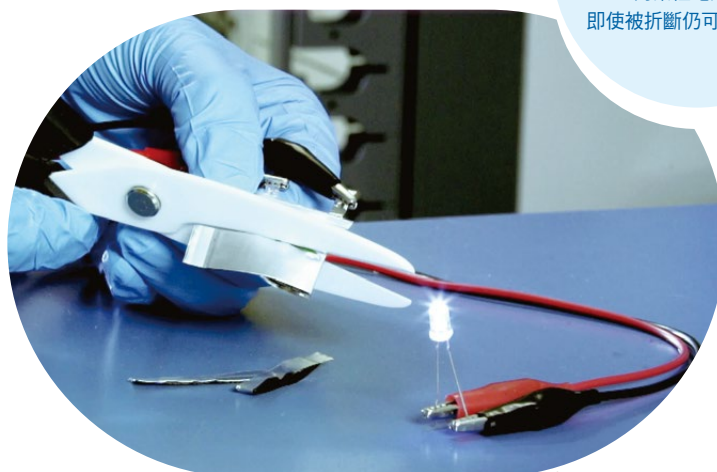

Technological
Achievement
Award
科技成就獎



Well Being Digital Limited
衛保數碼有限公司

Well Being Digital Limited (WBD101) targets to build the world's largest suite of preventive healthcare IoT devices with technologies used by tier 1 brands. We have been developing highly accurate sensing technology that can sense physiological data namely dynamic heart rate, VO2max, balance and gait and stress etc.

Our R&D focus on using Photoplethysmography (PPG) technology that can be more comfortable when applied on hearables/wearables than the traditional ECG, and through our patented multiple-sensor approach, we managed to reinvent PPG for dynamic usage even if the consumers are moving around.

We have more than 37 patents from USA, Europe, China, Hong Kong etc. Our technology has also won multiple international and local awards including Best Wearable Mobile Technology Award at Mobile World Congress 2016, the Special and Gold Awards at the 43rd Geneva Inventions Convention, besides licensing to Tier 1 wearable brands such as Parrot (Famous French IoT company), Muzik

衛保數碼有限公司(WBD101)致力開發及研究世界上最廣泛的預防醫療物聯網設備的套件。我們亦致力於開發高度精確的傳感技術，可以感知的生理數據，實時動態心率，最大攝氧量，平衡和步態和壓力等。

我們的研發重點是使用光電容積技術(PPG)應用在可聽及穿戴設備上，並通過我們的專利多傳感器方法的設計，這相對於傳統的心電圖更舒適。另一方面，我們成功重新發明PPG，用家走動時使用亦不會影響其準確性。從我們的技術，我們為可穿戴設備開發商/品牌提供極為精確的心率測量技術(ActivHearts™)，用戶能透過監測以避免過度運動。

我們有超過37項來自美國、歐洲、中國、香港等專利，我們的技術也獲得了多個國際及本地獎項，包括在Mobile World Congress 2016年的最佳可穿戴式的移動技術獎，在第43屆日內瓦發明大賽獲得特別金獎。我們亦會向不同的品牌作出

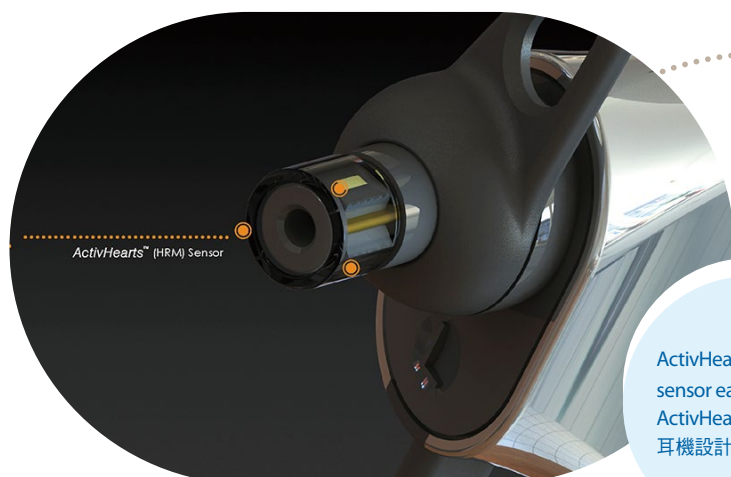

ActivHearts™ multiple-sensor earphone design
ActivHearts™ 多傳感器耳機設計

Dynamic heart rate sensing photoplethysmogram (PPG) theory
PPG 動態心率感應理論



The Special and Gold Awards at the 43rd Geneva Inventions Convention
第43屆日內瓦發明大賽金獎

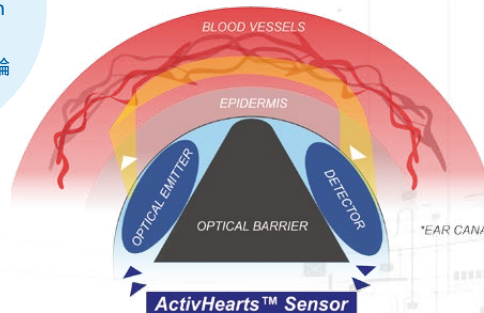

(a Twitter investment) and also to the World's Biggest Heart Rate chest belt brand.

Parrot SA CTO reflected in a testimonial to us that they "tested ActivHearts™ during more than 1000 accumulated miles on different type of users: ear shape, gender, skin color and during varied conditions: cold, hot, wet, sunny. Whatever the environment, ActivHearts™ data was always extremely close to the reference ECG even during intense interval running...!"

We are looking for people with B2C products or services knowledge that touch on the areas of preventive healthcare and we wish to partner with them cost effectively to bring our technology towards the preventive healthcare IoT devices market.

許可如Parrot (法國著名物聯網公司)、MUZIK (Twitter的投資公司)，以及世界上最大的心率Chestbelt品牌。

Parrot的首席技術人員指出：「他們對ActivHearts™在不同類型的用戶下進行累計多於1000英里的測試，其中對於不同的：耳朵的形狀，性別，膚色，並在各種天氣條件：冷、熱、濕、陽光下進行測試。在任何環境，ActivHearts™的數據即使在運動進行激烈期間，總是非常接近參考的心電圖...」。

我們正在尋找具熟悉B2C產品或服務知識的人材（關於預防保健等領域），我們希望尋找合作夥伴，把我們的技術有效地打進預防醫療物聯網設備市場。



Best Wearable Mobile Technology - Mobile World Congress 2016
世界行動通訊大會(2016)最佳可穿戴式的移動技術獎

Technological
Achievement
Certificate
of Merit

科技成就優異證書



4M Industrial Development Limited
科文實業有限公司



4M combines hands-on fun with virtual excitement in AR Wonder series that greatly stimulate children's imagination and creativity.

4M 打破傳統，引用AR 虛擬實境科技 注入教育玩具，激發兒童想像力

Established in 1993, 4M's mission is to develop creative toys that stimulate a child's natural imagination and make learning fun. While we value the role of traditional toys in a child's life, we also pursue the positive influence that innovation can bring with an appreciation of emerging technologies like augmented reality (AR). This technology inspired us to develop a new series, AR Wonder, which leads the way in fusing physical play with digital technology through hands-on fun augmented with virtual excitement. With Dinosaur DNA toy kits, children can 'excavate' and reconstruct a dinosaur skeleton like a paleontologist, then use an app to visualize the living dinosaur through AR technology. The app also allows them to capture images and videos to post to social media, so they can share a world of wonder and the thrill of discovery with families and friends.

(From left)
AR Wonder: Triceratops,
Tyrannosaurus Rex,
Stegosaurus
(左起) AR Wonder :
三角龍、暴龍、劍龍

科文實業有限公司自1993年成立以來，一直致力研發創新益智的教育玩具，發掘小朋友的無窮想像力，讓他們通過遊戲探索新知、啟迪思維。我們深明傳統玩具對兒童成長的重要性，因此特別注重玩具的創新元素。與此同時，我們亦留意到現代科技的應用潛力，其中近年新興的擴增實境 (AR) 技術觸發了我們的創作靈感，成功開發出全新的AR Wonder系列，引領新一代教育玩具潮流。

透過AR技術，系列中的Dinosaur DNA玩具融合實體及虛擬的玩法，將玩樂體驗昇華至更高層次。Dinosaur DNA產品讓小朋友化身成考古學家，動手挖掘並組裝恐龍骨架模型，並透過支援的應用程式，利用AR技術將恐龍活現眼前，享受和史前恐龍互動的樂趣。此外，小朋友還可即時拍照和攝錄，把創作的恐龍故事上載到社交網絡，分享他們的創意作品。





Cenique Infotainment Group Limited
怡能媒體有限公司

Technological
Achievement
**Certificate
of Merit**
科技成就優異證書



IntelliSense AVA
匿名觀眾分析

An emerging leader in Retail and Digital Out of Home (DOOH) industry, Cenique provide DIY and SME markets the next generation Intelligent Digital Signage and Audience Measurement Solutions. IntelliAd is a Digital Signage solution designed for commercial environments that can run on Android platform. Low cost media players and robust cloud based solution help you to centrally manage your digital signage network. IntelliSense Audience Measurement provides shopper analytics in the retail setting. It answers questions about the effectiveness and ROI of digital signage, and is both real-time and hands-free, automatically collecting and reporting insightful information about your customers.

Cenique's solutions are used by customers on most continents around the Globe in applications ranging from brand owners, retail chains, advertising network operators, corporations, professional baseball and basketball teams, universities, etc. Cenique is headquartered in Hong Kong with offices in North America and distributions points around the world. Visit www.cenique.com to learn more about our products and how we can work with you and your industry.

怡能媒體有限公司作為零售與戶外廣告行業的新領袖，為中小企市場提供新一代的數字標牌及觀眾測量解決方案。IntelliAd 是一種專為企業而設的數字標牌軟件，並運作於安卓平台。低成本的媒體播放器以及龐大的雲端，協助企業能夠中央管理數字標牌網絡。怡能的另一產品IntelliSense 匿名觀眾分析技術，提供零售店裡的顧客分析，回答有關數字標牌成效與投資回報的問題。此技術是即時性和免提性，能夠自動收集及匯報重要的顧客資訊。

怡能的解決方案被應用在全球各地的品牌商、零售連鎖店、廣告網絡營運商、企業、職業棒球隊、籃球隊和大學等等。怡能的總部設置在香港，北美地區與世界各地也設有辦公室和分佈點。歡迎瀏覽怡能官方網站www.cenique.com，更了解我們的產品，探討怡能怎樣與你和你的行業合作。



Technological Achievement Certificate of Merit

科技成就優異證書



ClusterTech Limited
聯科集團 (中國) 有限公司

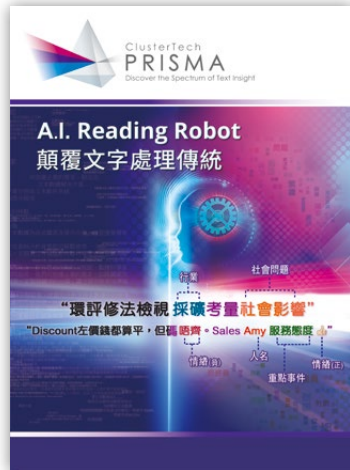

PRISMA - A.I. Reading Robot
Overturning Traditional Text Processing
PRISMA - A.I. Reading Robot
顛覆文字處理傳統

ClusterTech is a leading provider of advanced computing solutions and consulting services in the Asia-Pacific region. We develop and deploy solutions based on Cloud Computing, High Performance Computing, Business Intelligence and FPGA technologies to solve challenging technical problems and to improve operational efficiency of companies.

PRISMA is an innovative and state-of-the-art text processing technology invented by ClusterTech to empower business intelligence. It consists of 3 core technologies including "Search Engine", "Text Mining", and "(Trilingual) Natural Language Processing (NLP)*". In the past, text documents relied heavily on manual reading and handling. Now, structured and unstructured text data including Cantonese slang, idioms and buzzwords can be understood and automatically categorised by PRISMA.

聯科集團是亞太地區的一間提供領先計算科技解決方案和顧問服務的公司。我們基於雲計算、高性能計算、商業智能和FPGA等技術研發和打造一系列解決方案，幫助企業解決極具挑戰性的技術難題，從而提升其營運效率。

PRISMA是聯科集團自行研發的一個創新且獨特的文本處理技術，由三大核心技術組成 — 搜索引擎技術、文本挖掘技術及自然語言（兩文三語）分析技術*，使企業有效利用商業智能擴展業務。PRISMA能系統地整合以往需依賴人手處理的結構化資料（Structured Data）及非結構化資料（Unstructured Data），包括企業內部文檔、中英混合語句、繁簡字體混合語句、口語、潮語等。



3 Core Technologies of PRISMA
PRISMA 3大核心技術

* The Natural Language Processing (NLP) Technology in PRISMA is unique. It is capable of processing trilingual texts (Traditional Chinese, Simplified Chinese and English) simultaneously, and is tailor-made for the multi-cultural Hong Kong market.
此為PRISMA獨有的自然語言分析技術，能同時處理兩文三語文字。



Digpro Group Limited
迪普集團有限公司

Technological
Achievement
Certificate
of Merit
科技成就優異證書

The rise of e-commerce prompted Digpro Group Ltd. to develop a 360° AR Multimedia Photography System which is an effective product photography solution for SMEs and large multinational corporations.

The Digpro 360° AR Multimedia Photography system is single-handedly designed, produced and sold by Digpro Group. Whether in technology or competitiveness, Digpro occupies the leading position in the world, and has also obtained multiple application patents in major markets and countries.

The idea behind the Digpro 360° AR Multimedia Photography System is to allow anyone, without superb photography skills, to shoot white, shadow-free photos, AR and 360° images with an ordinary automatic digital camera. The process does not require any post-processing. In only a few simple steps, an AR or 360° image can be made. It can be used right on a phone, tablet or computer to greatly reduce costs and save time.

With a 360° AR display of a product, businesses can highlight the advantages of their product, and customers can also regain the experience of in-store shopping.



Digpro 360° AR Multimedia Photography System
迪普360° AR 多媒體攝影系統



Scan the QR code for 360 Demo
掃瞄二維碼觀看360示範

電子商務的興起，促使迪普致力開發360° AR 攝影系統，為各中小企及大型跨國企業提供一個具效益的商品攝影解決方案。

迪普360° AR多媒體攝影系統由設計、生產到銷售都由迪普一手包辦。無論技術和競爭力，迪普都一直處於世界領先地位，亦於主要市場及國家獲得多個應用專利申請，創造出百分百屬於香港，獨一無二的多媒體360° AR 攝影系統。

迪普360° AR 多媒體攝影系統的理念是任何人士不需依賴高超的攝影技巧，透過一部普通的自動數碼相機已經可以拍出純白、無陰影的相片製作 AR 及360° 影像。過程不需經過任何後期處理，簡單幾個步驟便可完成一個360° AR 影像，直接於手機、平板和電腦上使用，大大減省成本和時間。

以360° AR 全方位展示產品，商家既可突顯產品的優勢，客人亦可重拾實體商店購物的樂趣。

Technological
Achievement
Certificate
of Merit

科技成就優異證書



Eggplant Technologies Limited
茄子科技有限公司

Founded in Dec 2014, Eggplant Technologies focuses on developing smart home device and health relative products. We started project Move It in July 2015 with the goal of giving everyone - from beginners to higher-level fitness enthusiasts - a convenient and engaging way to work out. By bridging fitness with today's mobile centric subculture, our unique modular personal gym unit was created by a group of passionate designers, software and hardware engineers and developers.

After over a year of meticulous work, we are proud to introduce something that could potentially help enrich the daily lives of the people who use it. While Move It is ready to change and improve your workouts, we've only just begun to come up with even more new and exciting ways to deliver the ultimate fitness experience!

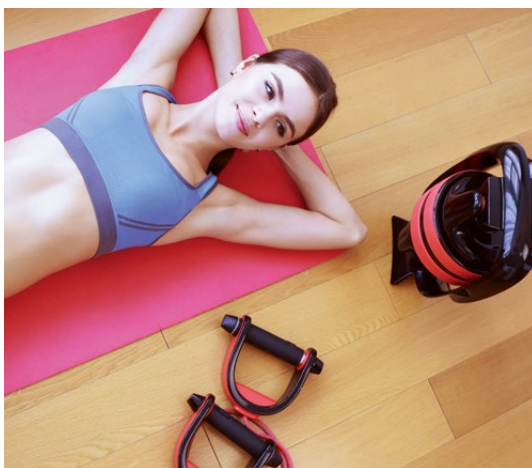

Move It makes an efficient workout anytime anywhere.
Move It 助你隨時隨地進行有效的鍛煉。

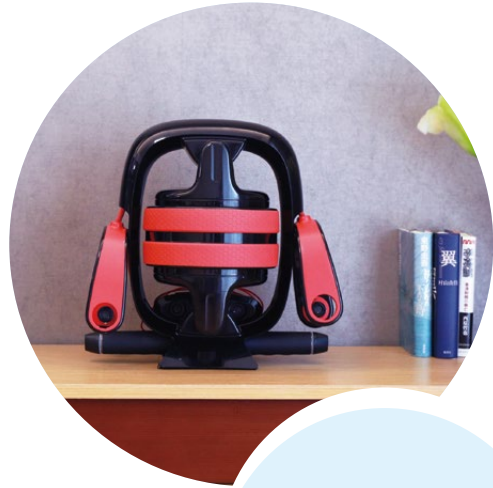

With a sleek, compact design,
Move It fits to any space at
home or office.
簡潔、有型、小巧的設計，
Move It 與你的家或辦公室融為
一體。

茄子科技成立於2014年12月，專注於開發和設計智能家居和健康相關的產品。我們於2015年7月啟動了產品 Move It 的研發，目標是希望讓所有人—無論是初學者，還是更高級別的健身愛好者，都能以一種方便且有效的鍛煉方式，通過 Move It 獨創性的模塊化並且輕便的健身設備和移動設備完成鍛煉。我們的這款“個人移動健身房”— Move It，是由一群充滿激情的設計師、軟件和硬件工程師和開發人員一起創建，希望能帶給更多人一種新的和令人興奮的健身體驗！



Farm66 Investment Limited
綠芝園投資有限公司

Technological
Achievement
Certificate
of Merit
科技成就優異證書



Unique planting system innovates urban agriculture. Varieties of our high quality, fresh vegetables are available to the local market.

獨特的種植系統，創新了城市農業。多種培植出的優質新鮮蔬菜供應於本港市場。

We are facing many challenges in food production while we demand food that are both contamination-free and environmental-friendly. Farm66 has been the pioneer in achieving this goal in Hong Kong for many years. Since 2010, Farm66 has been investigating the concept of urban farming and has been successfully developing their own technologies to achieve excellent optimized results: "Multi-layer Vertical Planting Structure", "Soilless Hydroponics Farming Technique", "Indoor Aquaponics Farming Ecosystem" and "Energy-efficient LED Wavelength Farming". These techniques enable dense cities like Hong Kong to revitalize industrial buildings, basement and utilize enclosed areas so that communities can achieve local-farming, create new jobs, and develop an efficient sustainable urban agricultural development plan.

Farm66's urban farming system has been awarded a patent in 2014. In 2015, Farm66 has been awarded the "HKPC: CarbonSmart Award" and "HKAI: Equipment and Machinery Design Award". Our team has been invited by overseas organizations for designing and consulting numerous commercial urban farming projects. Farm66 urban plant factory has been supplying high-quality vegetables to local premium supermarkets for years.

為增加本地農作物的自給率及市民對農作物安全和品質的信心，「綠芝園」由2010年開始積極研究室內大規模的種植可行方案，以科學實驗及技術實踐，成功於本港研發出一套可工廠式生產的種植系統，融合了多種科技技術：「多層式垂直種植結構」、「無土水耕技術」、「魚菜共生生態循環」及「節能LED光波種植技術」。此系統除可應用於活化工廈外，也可善用城市中不同的室內空間，如屋苑會所、地庫、學校實驗室、岩洞和前石礦場等，締造綠色社區及增加本地就業，配合市區可持續發展及農業科技發展的遠景。

「綠芝園」工廠式種植系統在2014年獲香港專利註冊外，於2015年獲香港生產力促進局「商界減碳建未來」嘉許及香港工商業：設備及機器設計獎，更被多個國家的機構邀請設計及建立植物工廠方案。蔬菜質量亦被高檔超市採購。



Mr. Gordon Tam, founder of Farm66, is assessing the healthiness of vegetables and fishes. 綠芝園創辦人譚嗣豪先生正在評估蔬菜及魚的生長健康狀況。

Technological
Achievement
Certificate
of Merit

科技成就優異證書



Seve Studio

Seve Studio was founded in 2002 in Hong Kong, specializing in design, development and manufacture of advanced automatic machinery. In addition to our standard product offerings, we provide professional CAD/CAM training courses, and bespoke services to our premier worldwide customers including tailor-made machinery and end-to-end solutions.

We are proud two time recipients of the prestigious 'Equipment and Machinery Design Award' of the Hong Kong Awards for Industries. In addition to our award-winning 4-axis CNC Engraving & Milling Machine and 3D Laser Printer, our products also include Multi-Axis Engraving & Milling Machine, Turning & Milling Composite CNC Machine, Laser Cutting & Engraving Machine and much more. Apart from our exceptional product range, our bespoke solutions and tailor-made machines and furniture are now in many offices, workshops, schools (STEM laboratories), and factories.

By pursuing genuine innovation, never compromising quality and dedication to best customer service, we have attracted customers from all over the world. Our product design, performance and services have earned unsurpassed customer satisfaction and loyalty. Our solutions have been applied by leading educational institutes and manufacturers in the Moulding, Toys, Jewelry, Watches & Accessories, Interior Design and Prototyping industries to name a few.

With the many cutting-edge designs and products in our pipeline we have a comprehensive plan to engage, embrace and lead the future of manufacturing technology.

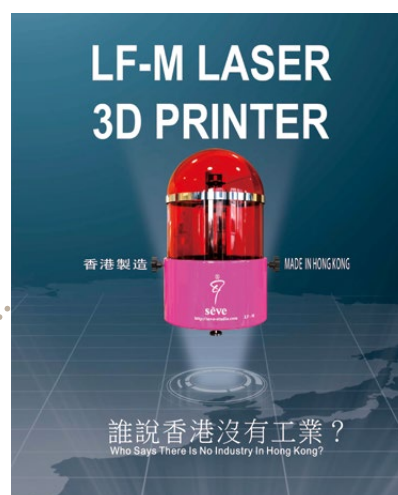

LF-M LASER 3D PRINTER
Hi-Tech Product – Affordable Price
High Speed • High Accuracy • High Efficiency
激光立體打印機
高科技產品 — 普及化價格
高速、高精度、高效能

Seve Studio公司2002年成立於香港，公司主要項目除了自主設計、研發及生產機械設備外，更為各行業客戶度身開發及訂製自動化機械設備等。公司多年來致力推廣CAD/CAM專業及教育培訓。

Seve Studio成立十多年期間，已於2004及2014年先後2次榮獲香港工商業獎之「設備及機器設計」獎項。除了獲獎機器之四軸電腦數控雕銑機及SLA激光立體打印機外，機械產品還包括：多軸電腦數控雕銑機、電腦數控複合車銑機、雷射激光切割機。另外還有為辦公室、學校STEM教室及工廠訂制不同的室內自動化傢俱及設備等。

Seve Studio憑著追求機械產品創新、高質量以及提供優良客戶服務為目標，得到模型、玩具、珠寶飾品、鐘錶、產品開發、及室內設計等行業之設計師、生產商及教育機構所採用。客戶至今已分佈各地。



Spring Eco-Tech Limited
淵源綠色科技有限公司

Technological
Achievement
Certificate
of Merit
科技成就優異證書

MagicFlex is SuiRich's patented technology. This rubber flexible LED display can be applied on wide ranges of indoor applications. Since launched into market in 2008, MagicFlex received many awards from innovation organisations in EU, HK and China. MagicFlex is light in weight and is the thinnest among similar LED display product, which makes it very easy to be installed. Its good quality has been proven by the clients' feedbacks after installed in different countries for 5-7 years. In recent years, MagicFlex is being adapted for many unique and creative projects for shopping malls and landmarks. In view of the current market demands, our MagicFlex can support the pitch ranges from 2mm to 10mm upon projects requirements, and hence can be applied in different environments. With over 15 years of experience in the LED industry, our professional team truly understands the market needs. We will keep investing in the development of state-of-the-art technology that brings benefits to business partner worldwide.

柔軟矽膠LED屏是淵源綠色科技的專利技術產品。它適合應用在室內廣泛顯示屏和燈飾藝術設計。自2008年在市場推出後，榮獲世界各地認可並獲科技創新獎。由於它利用創新技術和獨特的材料設計，現時是同類LED顯示屏產品中最輕、最薄和最易安裝的，深受世界各地用家喜愛，客人並在安裝多年的項目中，對這軟屏的質量穩定作很高的評價。近年越來越多有創意和有特色的項目也採用，包括地鐵圓柱體、大型商場、藝術館、高級會所等。隨著市場客人對產品的更高要求，我們專業團隊不斷突破，現在產品的技術已由點距10毫米發展到2毫米，以滿足不同項目的需求，更為各地用家和設計師創做更大商業和藝術應用價值。勇於創新和挑戰，是我們公司未來的發展方向。



Patent Magicflex installed in London UK
since 2011
專利矽膠柔軟 LED 屏安裝在英國倫敦自
2011 年

Technological Achievement Certificate of Merit

科技成就優異證書

TECHNOFORM GROUP



Technoform BAUTEC Hong Kong Limited
香港泰諾風保泰有限公司



Total solution for windows, doors and facades
門窗幕牆整體解決方案

For over 30 years, Technoform Group has been developing and producing high precision insulating strips. We provide thermal insulation and application solutions for customers in windows, doors and façade industries. Nowadays, the most common window systems used in Hong Kong are all non-thermal broken, which have the drawback of high thermal conduction between indoor and outdoor, causing more energy wasted for indoor air conditioning.

The high precision thermal strip is made of glass fiber reinforced polyamide 66, with complex geometry and low thermal conductivity. It can reduce the thermal transmittance of windows effectively and turns them into the high performance energy saving windows.

The 64mm series thermal strips are our new product development tailor-made for high performance Passive House windows. It allows users of residential and commercial buildings to achieve an excellence saving of energy cost for air conditioning by more than 10% per year. This product has significant contribution to energy saving, living comfort and reduction in carbon dioxide emissions.

泰諾風集團公司致力於設計、開發和製造高精度隔熱條，為全球門窗及幕牆行業提供隔熱解決方案和組裝解決方案。目前，香港地區建築普遍使用普通的鋁合金門窗，日常使用中室內外熱量傳遞較大，使得室內空調負荷過高，浪費電力資源。

我們採用尼龍66和玻璃纖維為原材料，使用高度精密的擠壓技術複合擠壓出的隔熱條，具有複雜多樣設計，導熱率極低，有效降低熱量通過鋁型材傳導，應用在鋁門窗後能使普通鋁門窗銳變為具有高保溫性能的隔熱窗。

被動房門窗用64mm系列隔熱條是我們近期研發的應用於高效保溫被動房的重要門窗構件。最為卓越的是，與普通鋁門窗相比，使用64mm系列隔熱條的被動窗能降低香港地區住宅和商業大廈每年10%以上的空調用電量，為用戶長期節約能源成本，提高居住舒適度，減少二氧化碳排放量，做出顯著的貢獻。

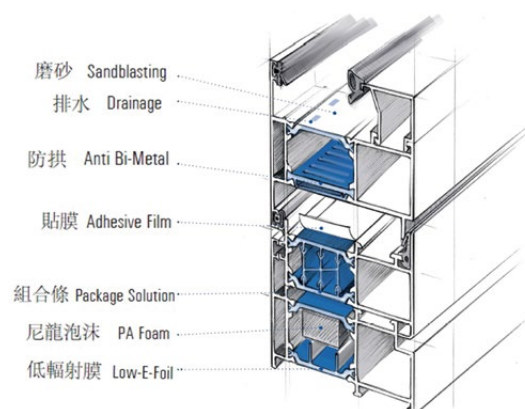

Application of thermal break strips in windows, doors and facades
隔熱條應用於門窗幕牆



鳴謝 ACKNOWLEDGEMENTS

白金贊助機構 PLATINUM SPONSORS



金贊助機構 GOLD SPONSORS



銀贊助機構 SILVER SPONSORS



其他贊助機構 OTHER SPONSORS



讓創意 閃爍未來



科學園匯聚超過600間科創企業進行尖端科技研發，我們發展三大科技平台，包括提升效率的**智慧城市**解決方案、提供更優質生活的**健康老齡化**科技，及應用於醫療、家居、教育及工業的**機械人技術**，推動科研發展，讓創意締造更美好未來。



觀看最新視頻，
探索科學園更多
資訊！



智慧城市



健康老齡化

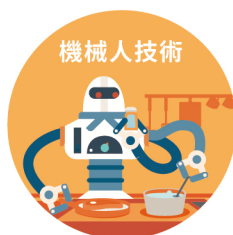

機械人技術

hkstp.org



HKSTP
香港科技園